

MotorGuide®

REPAIR PARTS

Model: POWER *plus*
ET54
ETP54

SPECIFICATIONS:

Year of Intro	2000
Thrust	54LBS
Volts	12VDC
Amp Draw	0 to 48 amps
Mount	09 Transom or 01P Pontoon
Speeds	5/2

PARTS ORDERING & TECH ASSISTANCE

MotorGuide Consumer Relations
 Phone 918-831-6989
 Fax 800-982-8093

Returned Goods must be accompanied with a Returned Goods Authorization. Contact MotorGuide Consumer Relations to obtain RGA.

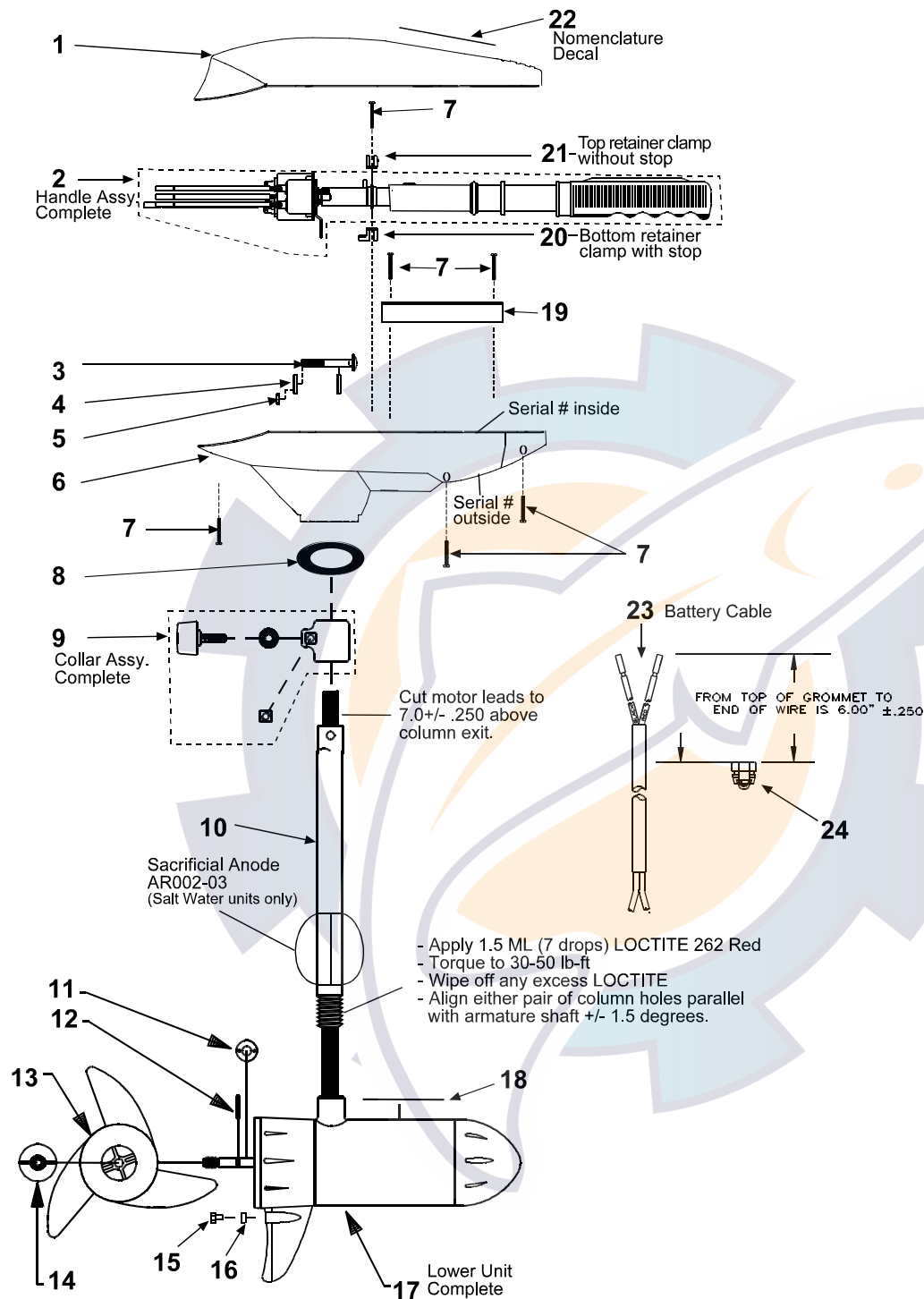

- Apply 1.5 ML (7 drops) LOCTITE 262 Red
- Torque to 30-50 lb-ft
- Wipe off any excess LOCTITE
- Align either pair of column holes parallel with armature shaft +/- 1.5 degrees.

KEY	DESCRIPTION	PART #	KEY	DESCRIPTION	PART #	KEY	DESCRIPTION	PART #
1	TOP HOUSING COVER BLACK	ET053-17	10	COLUMN 36"	TT049-05	16	ANODE (Saltwater models only)	AR002-02
2	HANDLE ASY	BT372-09	11	COLUMN 42"	TT049-06	17	MOTOR	DF397-10
3	BOLT	TT134-02	12	COLUMN 50"	FR049-13	18	LOWER UNIT DECAL	ET060-08
4	CURVED WASHER	TT171-08	13	MONOFILAMENT WASHER	AR175-01	19	CABLE PLATE	AT155-06
5	NYLON LOCK NUT	XT098-02	14	PROP DRIVE PIN	BR102-01	20	BOTTOM RETAINER CLAMP	AR036-05
6	T/H BASE BLACK	ET004-16	15	PROP/3 BLADE	AF124-12	21	UPPER RETAINER CLAMP	AR036-04
7	#8 X 5/8 SCREW	AT141-01		PROP/2 BLADE	AF124-07	22	NOMENCLATURE DECAL	FT056-20
8	COLUMN SEAL	AT079-01		PROP NUT	AR099-01	23	BATTERY CABLE	XT328-07
9	DEPTH ADJUSTMENT COLLAR	AR158-01		ANODE BOLT (Saltwater models only)	DK133-01	24	GROMMET	GR019-01

LOWER UNIT BREAKDOWN

Model:
ET54

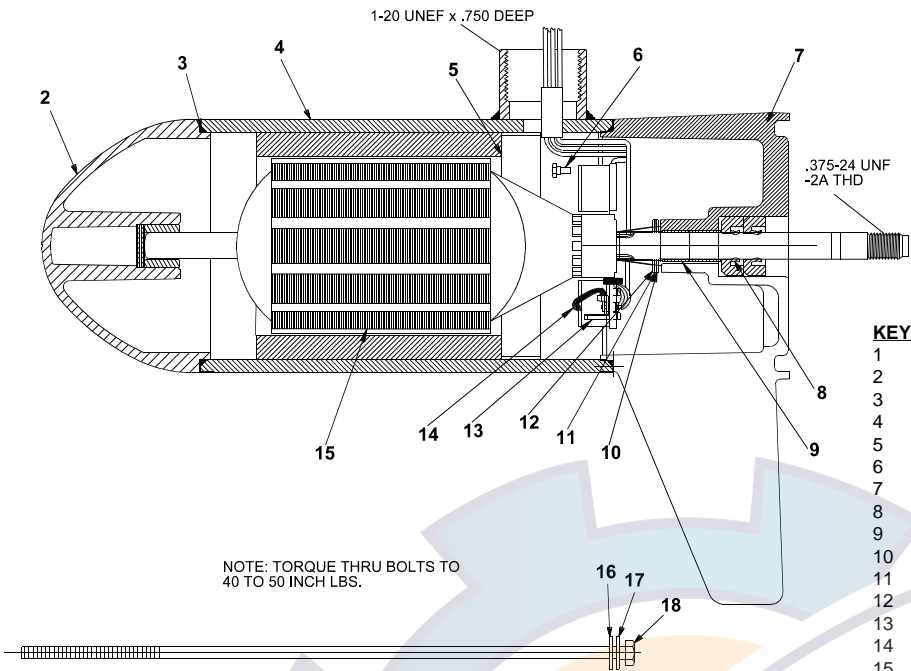

KEY	QTY	DESCRIPTION	PART NO.
1	X	MOTOR	DF397-10
2	1	NOSE CAP	XF3212-01
3	2	O RING SEAL	MR217-01
4	1	HOUSING ASY	JF3210-01
5	1	RETAINER	JF233-01
6	2	BRUSH CARD SCREW	MR228-01
7	1	COMM CAP	DF3205-06
8	2	SHAFT SEAL	MR223-01
9	1	BEARING	MR206-01
10	1	NYLATRON WASHER	MR226-01
11	1	WASHER	MR227-01
12	1	E RING	MR219-02
13	2	BRUSH SPRINGS	MR214-02
14	1	BRUSH ASY LESS SPRING	DF3201-01
15	1	ARMATURE	CF3207-02
16	4	STATIC SEAL	MR222-01
17	4	THRU BOLT WASHER	MR216-01
18	2	THRU BOLT	MR218-02

WIRING

